



LANDMARK LIFTS LTD

Freefone 0800 652 8138 Web www.landmarklifts.co.uk

STRATEGOS PLATFORM LIFT

Strategos Platform Lift

The 'Strategos' disabled access platform lift provides an ideal solution where the required lift travel height is between 500mm and 1999mm. The Strategos is a unique 'open aspect' platform system specifically designed for both internal and external locations.

Its substantial and rugged construction is hot galvanised steel as standard or can be powder coated giving a colour choice at extra cost. If the Strategos is not exactly what you desire, please give us a call as we may have other solutions!





TECHNICAL SPECIFICATION

Lifting Capacity	300kgs
Lifting Heights	Suitable for 500mm to 1999mm only
Drive System	Double screw and safety nut
Motor	2.5kW
Lifting Speed	60mm per second
Power Supply	400v; 3 phase (or 240v; single phase-at extra cost)
Overall Footprint	1300mm wide (plus clearance to both sides) x 2000mm long
Platform Size	1040mm wide x 1450mm long clear
Platform Finish	Aluminium non-slip tread-plate flooring
Control System	Constant pressure 'push to run'
Safety Features	Touch sensitive cut-off to underside of platform Hand lowering system (in event of power failure) Swing gates (inter-locked according to lift position)
Standards	CE marked in accordance with 'The European Machinery Directives' via SS 2097-7



STRATEGOS PLATFORM LIFT

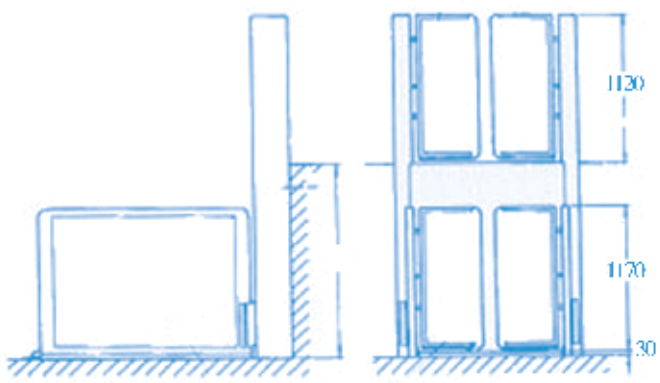

A*. Please contact us for further information

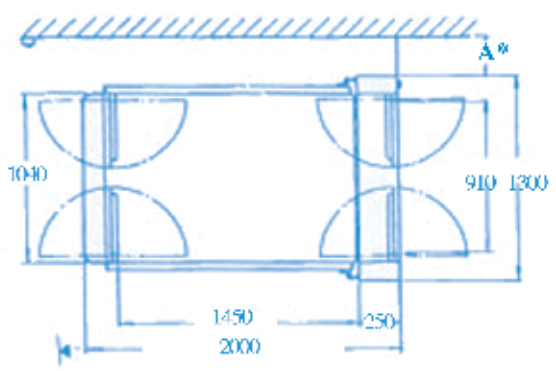

OPTIONS AVAILABLE

- Any RAL colour powder coating to all steelwork
- System for a single phase supply
- 90° adjacent entries
- Emergency telephone communication system

BENEFITS

- Short manufacturing time
- Site installation around 2 days
- Minimal builders work required
- Substantial / rugged construction
- Suitable for internal & external locations
- Pit construction - NOT REQUIRED
- No separate lift plant to locate

Note - all details are correct at time of completion, however, all data maybe subject to change without prior notice. These details cannot form part of a written contract.

ref:Strategos-08/08