



LANDMARK LIFTS LTD

Freefone 0800 652 8138 Web www.landmarklifts.co.uk

Low-Up Platform Lift

The 'Low-Up' disabled access platform lift provides an ideal solution where the required lift travel height is under 500mm. It is a unique 'open aspect' design intended for both internal and external locations.

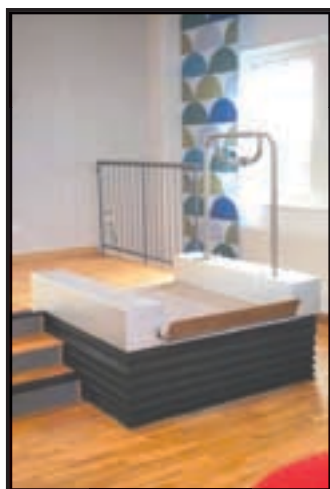

LOW-UP PLATFORM LIFT



TECHNICAL SPECIFICATION

Lifting Capacity	225kgs
Lifting Heights	From 200mm up to 500mm only
Drive System	Double scissor
Lifting Speed	10mm per second
Power Supply	240v; 50Hz single phase
Overall Footprint	1380mm wide x 1500mm long
Platform Size	915mm wide x 1340mm long
Platform Finish	Grey Altro safety non-slip flooring finish
Control System	Constant pressure 'push to run'
Safety Features	Bellows guarding to underside of platform
Standards	CE marked in accordance with 'The European Machinery Directives' 2006/42/EC



LOW-UP PLATFORM LIFT

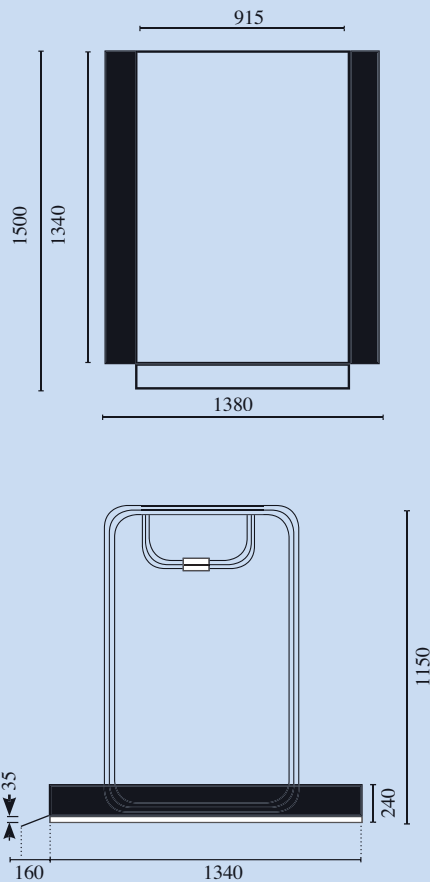

OPTIONS AVAILABLE

- Secure key switch operation
- Remotely located controls

BENEFITS

- Short manufacturing time
- Site installation normally 1 day
- Rugged construction
- Suitable for internal & external locations
- NO PIT REQUIRED**
- No separate lift plant to locate

Landmark Lifts Ltd. 29 Charter Gate, Quarry Park Close, Moulton Park, Northampton NN3 6QB
 t 0800 652 8138 f 01604 495 111 e info@landmarklifts.co.uk w www.landmarklifts.co.uk

Note - all details are correct at time of completion, however, all data maybe subject to change without prior notice. These details cannot form part of a written contract.

ref:Lowup-3/10